

Recognized as an
American National Standard (ANSI)

IEEE Std C37.11-1997
(Revision of ANSI Std C37.11-1979)

IEEE Standard Requirements for Electrical Control for AC High- Voltage Circuit Breakers Rated on a Symmetrical Current Basis

Sponsor

**Switchgear Committee
of the
IEEE Power Engineering Society**

Approved 20 March 1997

IEEE Standards Board

Approved 20 August 1997

American National Standards Institute

Abstract: Standard requirements for all types of electrical control circuits for ac high-voltage breakers rated above 1000 V are given. This standard is applicable for any type of power-operated mechanism and for both ac and dc control power. Only basic control elements of the circuit breaker, including reclosing where required, are included in this standard. Devices or circuits for protective relaying, special interlocking, etc., are not included.

Keywords: ac high-voltage circuit breakers, alarm circuits, auxiliary contacts, auxiliary switch, closing, control schemes, electrical control, grounding, heater circuits, metal-clad switchgear, metal-enclosed switchgear, motor circuits, opening, re-closing, tripping

The Institute of Electrical and Electronics Engineers, Inc.
345 East 47th Street, New York, NY 10017-2394, USA

Copyright © 1997 by the Institute of Electrical and Electronics Engineers, Inc.
All rights reserved. Published 1997. Printed in the United States of America

ISBN 1-55937-917-0

No part of this publication may be reproduced in any form, in an electronic retrieval system or otherwise, without the prior written permission of the publisher.

IEEE Standards documents are developed within the IEEE Societies and the Standards Coordinating Committees of the IEEE Standards Board. Members of the committees serve voluntarily and without compensation. They are not necessarily members of the Institute. The standards developed within IEEE represent a consensus of the broad expertise on the subject within the Institute as well as those activities outside of IEEE that have expressed an interest in participating in the development of the standard.

Use of an IEEE Standard is wholly voluntary. The existence of an IEEE Standard does not imply that there are no other ways to produce, test, measure, purchase, market, or provide other goods and services related to the scope of the IEEE Standard. Furthermore, the viewpoint expressed at the time a standard is approved and issued is subject to change brought about through developments in the state of the art and comments received from users of the standard. Every IEEE Standard is subjected to review at least every five years for revision or reaffirmation. When a document is more than five years old and has not been reaffirmed, it is reasonable to conclude that its contents, although still of some value, do not wholly reflect the present state of the art. Users are cautioned to check to determine that they have the latest edition of any IEEE Standard.

Comments for revision of IEEE Standards are welcome from any interested party, regardless of membership affiliation with IEEE. Suggestions for changes in documents should be in the form of a proposed change of text, together with appropriate supporting comments.

Interpretations: Occasionally questions may arise regarding the meaning of portions of standards as they relate to specific applications. When the need for interpretations is brought to the attention of IEEE, the Institute will initiate action to prepare appropriate responses. Since IEEE Standards represent a consensus of all concerned interests, it is important to ensure that any interpretation has also received the concurrence of a balance of interests. For this reason, IEEE and the members of its societies and Standards Coordinating Committees are not able to provide an instant response to interpretation requests except in those cases where the matter has previously received formal consideration.

Comments on standards and requests for interpretations should be addressed to:

Secretary, IEEE Standards Board
445 Hoes Lane
P.O. Box 1331
Piscataway, NJ 08855-1331
USA

Note: Attention is called to the possibility that implementation of this standard may require use of subject matter covered by patent rights. By publication of this standard, no position is taken with respect to the existence or validity of any patent rights in connection therewith. The IEEE shall not be responsible for identifying patents for which a license may be required by an IEEE standard or for conducting inquiries into the legal validity or scope of those patents that are brought to its attention.

Authorization to photocopy portions of any individual standard for internal or personal use is granted by the Institute of Electrical and Electronics Engineers, Inc., provided that the appropriate fee is paid to Copyright Clearance Center. To arrange for payment of licensing fee, please contact Copyright Clearance Center, Customer Service, 222 Rosewood Drive, Danvers, MA 01923 USA; (508) 750-8400. Permission to photocopy portions of any individual standard for educational classroom use can also be obtained through the Copyright Clearance Center.

The Standards Committee on Power Switchgear, C37, which reviewed and approved this standard, had the following personnel at the time of approval:

E. Byron, Chair

M. Calwise, Secretary

A. K. McCabe, Executive Vice-Chair of High-Voltage Switchgear Standards

J. C. Scott, Executive Vice-Chair of Low-Voltage Switchgear Standards

D. L. Swindler, Executive Vice-Chair of IEC Activities

<i>Organization Represented</i>	<i>Name of Representative</i>
Association of Iron and Steel Engineers.....	(vacant)
Electric Light and Power Group	G. Miller
	T. E. Bruck (<i>Alt.</i>)
	D. E. Galicia
	Joseph L. Koepfinger
	D. G. Komassa
	J. H. Provanzana
Institute of Electrical and Electronics Engineers.....	Keith Gray
	L. R. Beard
	T. A. Burse (<i>Alt.</i>)
	Ruben D. Garzon (<i>Alt.</i>)
	B. Haas (<i>Alt.</i>)
	Alec C. Monroe
	Bob Puckett (<i>Alt.</i>)
	Larry Schmidt
	John Wood
National Electrical Manufacturers Association	G. Sakats
	E. Byron (<i>Alt.</i>)
	Ruben D. Garzon
	Gary T. Jones
	W. Kracht
	H. L. Miller
	T. Olsen
	David L. Stone
	D. L. Swindler (<i>Alt.</i>)
Tennessee Valley Authority.....	D. N. Reynolds
Testing Laboratory Group.....	L. Frier
	P. Notarian
U.S. Department of the Army, Office of the Chief of Engineers	J. A. Gilson
U.S. Department of the Navy, Naval Construction Battalion Center.....	Romulo R. Nicholas
Western Area Power Administration.....	G. D. Birney

Introduction

(This introduction is not a part of IEEE Standard Requirements for Electrical Control for AC High-Voltage Circuit Breakers Rated on a Symmetrical Current Basis.)

This standard is a revision of ANSI Std C37.11-1979. This revision is editorial in nature. There are no substantive changes in Figures 1 through 8, nor of the requirements. The purpose is to bring this standard up-to-date and in line with present-day requirements for ac high-voltage power circuit breakers and to bring it into agreement with IEEE Std C37.100-1992, *IEEE Standard Definitions for Power Switchgear*.

As reflected in the title, this standard applies to ac high-voltage circuit breakers rated on a symmetrical current basis. A wide variety of control schemes is now in use by companies. Many of these users consider it essential that their particular scheme be continued so as to maintain unified operating practices within their company. It has been necessary, therefore, to set up certain preferred arrangements for wiring at the circuit breaker. These arrangements, in effect, constitute standards for production of the circuit breakers. They are, however, sufficiently versatile to permit the majority of users to connect the circuit breaker to their external circuits to achieve the required control scheme without changing the internal wiring of the circuit breaker. Diagrams of typical operating connections are included in this standard to demonstrate this versatility.

This standard includes only the basic control elements of the circuit breaker, including reclosing where required. It does not include devices or circuits for protective relaying, special interlocking, etc., since these are dependent upon the specific application of a particular circuit breaker. This standard is not intended to preclude the possibility of obtaining, as additional equipment, such devices or circuits, including auxiliary switches in excess of the specified minimum requirements, where necessary in a specific application.

It is not intended that the standard be considered inflexible as to future change. Future developments in both application and manufacturing, as well as further study of existing requirements, should result in revision and expansion of the standard.

The explanatory notes that appear in small type are included to give the user of this standard the reason or background for certain requirements.

This standard was first developed by the Committee on Power Circuit Breaker Control and the Committee on Electric Switching and Switchgear of the Association of Edison Illuminating Companies. The present revision was prepared by the Working Group for the High-Voltage Circuit Breaker Subcommittee of the IEEE Switchgear Committee. The Working Group included the following members:

R. William Long, *Chair,*

R. W. Alexander
D. J. Lemmerman

R. A. Sarkinen

H. M. Smith
B. F. Wirtz

The following persons were on the balloting committee:

Roy W. Alexander
J. G. Angelis
Richard H. Arndt
Chuck Ball
L. Ronald Beard
Harvey L. Bowles
Matthew Brown
John H. Brunke
Ted Burse
Raymond L. Capra
Alexander Dixon
J. J. Dravis
C. J. Dvorak
P. W. Dwyer
Ruben D. Garzon
Keith I. Gray
Kenneth Hendrix
H. L. Hess
Jerry M. Jerabek

P. L. Kolarik
David G. Kumbera
Stephen R. Lambert
Ward E. Laubach
John G. Leach
George N. Lester
Don Lott
E. L. Luehring
Andrew K. McCabe
Lawrence V. McCall
William C. McKay
Nigel P. McQuin
Don C. Mills
Alec C. Monroe
Georges F. Montillet
F. J. Muench
James F. O'Donnell
Raymond P. O'Leary
A. F. Parks

David F. Peelo
G. O. Perkins
R Kris Ranjan
J. C. Ransom
David N. Reynolds
H. C. Ross
Tim E. Royster
Larry H. Schmidt
C. A. Schwalbe
Devki N. Sharma
Guy St. Jean
Alan D. Storms
D. L. Swindler
John S. Tannery
S. H. Telander
Frederick C. Teufel
Thomas J. Tobin
Edward F. Veverka
Charles L. Wagner

When the IEEE Standards Board approved this standard on 20 March 1997, it had the following membership:

Donald C. Loughry, *Chair*

Richard J. Holleman, *Vice Chair*

Andrew G. Salem, *Secretary*

Clyde R. Camp
Stephen L. Diamond
Harold E. Epstein
Donald C. Fleckenstein
Jay Forster*
Thomas F. Garrity
Donald N. Heirman
Jim Isaak
Ben C. Johnson

Lowell Johnson
Robert Kennelly
E. G. "Al" Kiener
Joseph L. Koepfinger*
Stephen R. Lambert
Lawrence V. McCall
L. Bruce McClung
Marco W. Migliaro

Louis-François Pau
Gerald H. Peterson
John W. Pope
Jose R. Ramos
Ronald H. Reimer
Ingo Rüsich
John S. Ryan
Chee Kiow Tan
Howard L. Wolfman

*Member Emeritus

Also included are the following nonvoting IEEE Standards Board liaisons:

Satish K. Aggarwal
Alan H. Cookson

Kim Breitfelder
IEEE Standards Project Editor

Contents

1. Overview.....	1
1.1 Scope.....	1
1.2 Purpose.....	1
2. References.....	1
3. Functional requirements.....	1
4. Devices and auxiliaries	3
5. Wiring requirements	4

IEEE Standard Requirements for Electrical Control for AC High-Voltage Circuit Breakers Rated on a Symmetrical Current Basis

1. Overview

1.1 Scope

This standard applies to all types of electrically controlled ac high-voltage circuit breakers rated above 1000 V. This standard applies for any type of power-operated mechanism and for both ac and dc control power. Only the basic control elements of the circuit breaker, including reclosing where required, are included in this standard. This standard does not include devices or circuits for protective relaying, special interlocking, etc., since these are dependent upon the specific application of a particular circuit breaker.

1.2 Purpose

The purpose of this standard is to establish basic requirements for ac high-voltage power circuit breaker control schemes so that users and manufacturers can effect engineering and production economies by reducing the multiplicity of special control schemes that are specified in the absence of standards.

2. References

This standard shall be used in conjunction with the following publication. When a standard is superseded by an approved revision, the revision shall apply.

IEEE Std C37.100-1992, IEEE Standard Definitions for Power Switchgear (ANSI).¹

3. Functional requirements

The basic functional requirements of the control scheme for a circuit breaker include the following:

- a) The circuit breaker mechanism shall make one complete closing operation, including automatic cut-off of closing power, after an initiating control device has operated and the first device in the control

¹IEEE publications are available from the Institute of Electrical and Electronics Engineers, 445 Hoes Lane, P.O. Box 1331, Piscataway, NJ 08855-1331, USA.

scheme has responded, even though the contacts of the initiating control device are opened before the circuit breaker closing operation is completed.

NOTE—This requirement ensures that, after the closing operation has been initiated, a seal-in circuit will be provided, where necessary, so that the closing operation will be completed automatically, even though the operator releases the control switch before the circuit breaker is completely closed.

Some circuit breakers achieve complete closing by electromechanical means, even if the closing signal has been removed before the closing operation is complete.

Control schemes in which the seal-in circuit or the equivalent is disconnected or made inoperative are objectionable because of the hazard to circuit breaker performance.

There are some definite purpose circuit breakers, with mechanisms specially designed to be able to open and interrupt safely, even during a closing operation, (i.e., before the circuit breaker has fully closed). Circuit breakers of this type are not subject to this requirement.

- b) Only one closing operation of the circuit breaker mechanism shall result from each close signal of an initiating control device, even though the circuit breaker trips while the initiating control device is still in the closed position.

NOTE—This requirement ensures that the circuit breaker will not “pump” if it trips during a closing operation. The trip operation may be due to a fault or a failure to latch.

- 1) The control scheme may allow reclosing in the event that control power is interrupted while the initiating control device remains closed. For example, reclosing is not disabled when the control circuit is intentionally opened and closed while checking for grounds.
- 2) The control scheme should not allow reclosing in the event that control power is lost or reduced in voltage as a result of the closing operation, while the initiating control device remains closed. A typical example is the case in which control power is obtained from the primary power system. When the circuit breaker closes into a fault, the primary power system voltage is reduced, and subsequently the control power voltage is also reduced.

NOTE—With maintained-contact type initiating devices, such as pressure switches, fluid-level switches, etc., lockout relays or other devices are necessary to prevent reclosure if control power is interrupted during, or subsequent to, a circuit breaker tripping operation while the initiating closing device remains closed.

- c) When power is removed from the closing control circuit during or after an incomplete closing operation, all electrically operated devices in the control circuit shall reset to the normal circuit breaker open position, except for those devices requiring a supply of control power in order for them to assume their normal circuit breaker open position.

NOTE—This requirement ensures that, if the control power supply is removed during an incomplete closing operation, all the control devices will restore to the normal circuit breaker open position so that an additional operation of the master control device will be required to close the circuit breaker. The reference to devices that require a supply of control power to assume their normal circuit breaker open position relates to control schemes that employ a reverse “Y” relay control.

- d) When the circuit breaker is in the closed position, the operation of a close control device shall not result in an operation of the circuit breaker mechanism.

NOTE—This requirement ensures against unnecessary mechanical operation of the circuit breaker mechanism, with accompanying shock and possibility of trip-out.

- e) When a closing operation of a circuit breaker utilizing stored energy, such as air, oil, or charged spring, etc., cannot be completed because of the absence of an adequate supply of stored energy, all actuating devices in the control circuit shall remain in the normal circuit breaker open position when the initiating close control device is operated.
- f) When the interrupting capability of a circuit breaker is dependent on gas density or gas pressure, and that capability is inadequate or would become inadequate as a result of a closing operation, both closing and opening operations of that circuit breaker shall be prevented.

NOTE—Manufacturers can make available additional switches to initiate an alarm or tripping of a closed circuit breaker when the dielectric strength can not be maintained or suitable isolation accomplished, and before the interrupting capability becomes inadequate.

- g) When the dielectric strength or interrupting capability of a circuit breaker is dependent on gas density or gas pressure, a switch shall be provided to initiate an alarm before the dielectric strength or interrupting capability becomes inadequate.

NOTE—Manufacturers can make available additional switches to initiate suitable isolation before the dielectric strength becomes inadequate.

- h) If a circuit breaker operating mechanism is mechanically trip-free, and intended for automatic reclosing service, or if it may be damaged when closing with the mechanism in a non-latched position, then the closing release shall not operate, even if a signal to close is given, unless the trip-free mechanism is in the latched position.
- i) The alarm circuits that monitor pressure shall be designed to avoid nuisance alarms due to transient pressure changes, when the circuit breaker is operated with normal operating pressures.
- j) For circuit breakers that are capable of individual pole operation, pole disagreement tripping should be provided when the three poles are intended to be gang-operated together.

4. Devices and auxiliaries

The following devices or auxiliaries shall be included in each circuit breaker as indicated:

NOTE—When the circuit breakers are the drawout type, some devices and auxiliaries may be located within the switch-gear assembly rather than on the drawout element.

- a) A manually operated control circuit disconnecting device of the visible-break type, such as a knife switch or a pullout fuse block, shall prevent both remote and local electrical operation of the circuit breaker, and shall open both polarities of the circuit together.

NOTE—The purpose of a visible-break type disconnecting device is that a visual open break in the circuit can be made for safety reasons. Single-pole fuses are not an acceptable means of disconnection since these entail the following inconveniences in operation:

- Require holders for the removed fuses
- Can allow unintended single-pole energizing of the circuit
- Are subject to failure if the fuse clips are spread repeatedly for removal and reconnection of fuses

In Figures 1 through 8, both sides of the ac power control circuits and auxiliary connections (e.g., heaters) are illustrated as fused. This arrangement is intended to define standard numbering for many cases. It is assumed that the user and the manufacturer will apply fundamental safety rules requiring the grounded sides of ac circuits to be solidly connected and, therefore, not fused.

When dc power is used for both closing control devices and tripping devices, the user should provide or specify a separate disconnecting device in the trip circuit if the user elects not to carry the trip circuit through the disconnecting device provided for the closing circuit.

- b) When ac power is used for closing and dc power is used for tripping, an additional two-pole manually operated control disconnecting device of the visible-break type, such as a knife switch or a pullout fuse block, shall prevent both remote and local electrical tripping of the circuit breaker, and shall simultaneously open both sides of the circuit. This device may be combined with the device specified in item a) to form a four-pole device.
- c) Overcurrent protection devices for the ungrounded sides of the closing power circuit shall be connected to, or made integral with, the disconnecting device specified in item a).

NOTE—Separate overcurrent protection devices have been omitted from the trip circuit because most users either:

- 1) Do not protect trip circuits, or;
- 2) Use protective devices external to the circuit breaker, or;
- 3) Connect the trip circuit through the closing circuit protective devices.

- d) In addition to the auxiliary switch contacts normally required for proper control of the circuit breaker operation and its indicating lights, as a minimum, the following extra auxiliary switch contacts shall be provided for utilization in the user's control circuits:
- 1) Circuit breaker NOT intended for use in metal-clad switchgear:
 - Two "a" contacts (open when the circuit breaker main contacts are open, and closed when the circuit breaker main contacts are closed) and two "b" contacts (closed when the circuit breaker main contacts are open, and open when the circuit breaker main contacts are closed).
 - 2) Circuit breaker intended for use in metal-clad switchgear:
 - Two "a" contacts and two "b" contacts when closing and tripping power are dc.
 - One "a" contact and one "b" contact when closing power is ac and tripping power is dc.

Where necessary to meet specific requirements, auxiliary switch contacts in addition to those specified may be made available by installing supplementary devices.

- e) When heaters are supplied, a manually operated disconnecting device with overcurrent protection shall be connected in the power supply to the heaters. This disconnecting device shall simultaneously open all source connections to the heater. Overcurrent protection devices for the ungrounded sides of the circuit shall be connected to each pole of, or made integral with, the disconnecting device.

In an enclosed switchgear assembly, only one set of disconnecting and overcurrent protection devices need be furnished for all heaters.

- f) When an individual motor is used for charging springs or for running a gas compressor or a hydraulic pump, etc., a manually operated disconnecting device of the visible-break type shall be connected in the power supply to the motor. The disconnecting device shall simultaneously open all source connections to the motor. Overcurrent protection devices for the ungrounded side of the circuit shall be connected to each pole of, or made integral with, the disconnecting device.
- g) When an electrically operated regulating valve is used to maintain pressure levels in a system using air or other fluid, a two-pole manually operated disconnecting device of the visible-break type and one two-pole or two single-pole overcurrent protection devices shall be connected in the supply to the regulating valve.

5. Wiring requirements

The wiring requirements for a circuit breaker include the following:

- a) Each circuit breaker shall be wired so that the individual components of the control circuit are electrically grouped, terminated, and identified with numerals as shown in Diagram A of Figures 1 through 8, as applicable for the particular type of circuit breaker.

Figures 1 through 8, inclusive, apply to circuit breakers as shown in Tables 1 and 2.

Table 1—Circuit breaker intended for use in metal-clad switchgear

Closing power	Closing control	Tripping control	Figure
dc	dc	dc	1
ac	ac	dc	2
ac	ac	Capacitor trip	3
ac	dc	dc	4

Table 2—Circuit breaker not intended for use in metal-clad switchgear

Closing power	Closing control	Tripping control	Figure
dc	dc	dc	5
ac	ac/dc	dc	6
ac	ac	Capacitor trip	7
Pneumatic/hydraulic	dc	dc	8

- b) The terminals intended for the user to connect the external control circuit wiring, and the terminals intended for making connections between control circuit groups, include the following:
- 1) Terminals for control circuit components specified in item a) above.
 - 2) Terminals for the extra auxiliary switches specified in Clause 4, item d).
 - 3) Terminals for the heater circuits and the individual motor circuits identified by numerals in Figures 1 through 8, inclusive.

These shall be readily accessible, closely grouped, and conveniently arranged for making connections between control circuit groups and for making connections to user's external wiring.

Further, the terminals of any auxiliary switch contacts in addition to those specified in Clause 4, item d), that may be available due to manufacturer's standard assemblies, or that may be supplied to meet user's specifications, should also be readily accessible, closely grouped, and conveniently arranged for making connections.

- c) Circuit breakers forming part of switchgear cubicles, or for use in metal-clad switchgear, that have all of the control and protective features self-contained, are exempt from the provisions of having closely grouped terminals convenient for making user's external connections.

NOTE—Terminals in Notes E, F, and G in Figure 8 are identified with suffix A, for additional pressure and temperature devices and trip circuits to meet user's specifications. This does not mean that these additional terminals must be physically located adjacent to the terminals without suffixes and provided on all circuit breakers, whether or not they are required.

- d) Before shipment, the manufacturer shall install the necessary removable jumpers between the various terminals so that when the circuit breaker is received, it will be operative after installation of the user's remote connections.

The proposal submitted to a purchaser in connection with an order for circuit breakers shall indicate the jumpers that the manufacturer plans to install before shipment, unless otherwise specified by the purchaser. Typical arrangements of jumpers are shown in Diagram B of Figures 1 through 8, inclusive, to illustrate some of the commonly used control schemes that are possible when the circuit breaker is wired in accordance with these standard schemes.

- e) When only one terminal of a coil is connected continuously to a supply bus, that terminal should be connected to negative on dc circuits or to neutral (when available) on ac circuits.
- f) When control contacts are provided in heater circuits, the control contacts shall be connected to an ungrounded source conductor.
- g) For circuit breakers equipped with dual trip releases, the control circuits for each trip coil shall be electrically independent. Loss of control power to one of the trip circuits shall not affect the function of the other trip circuit. Simultaneous operation of both trip releases shall trip the circuit breaker.

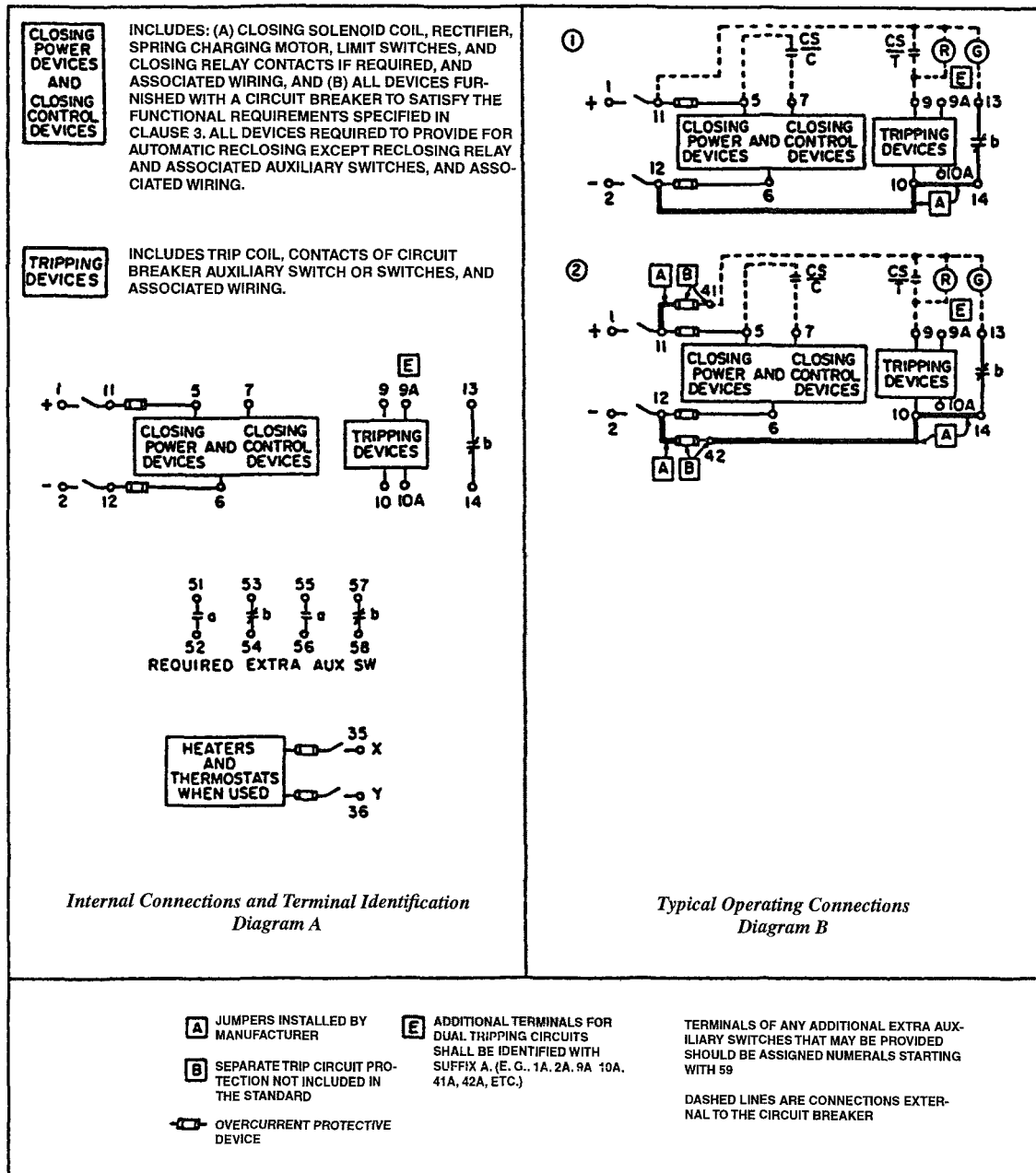

Figure 1—Circuit breaker intended for use in metal-clad switchgear, where

- The closing power is dc
- The closing control is dc
- The tripping control is dc

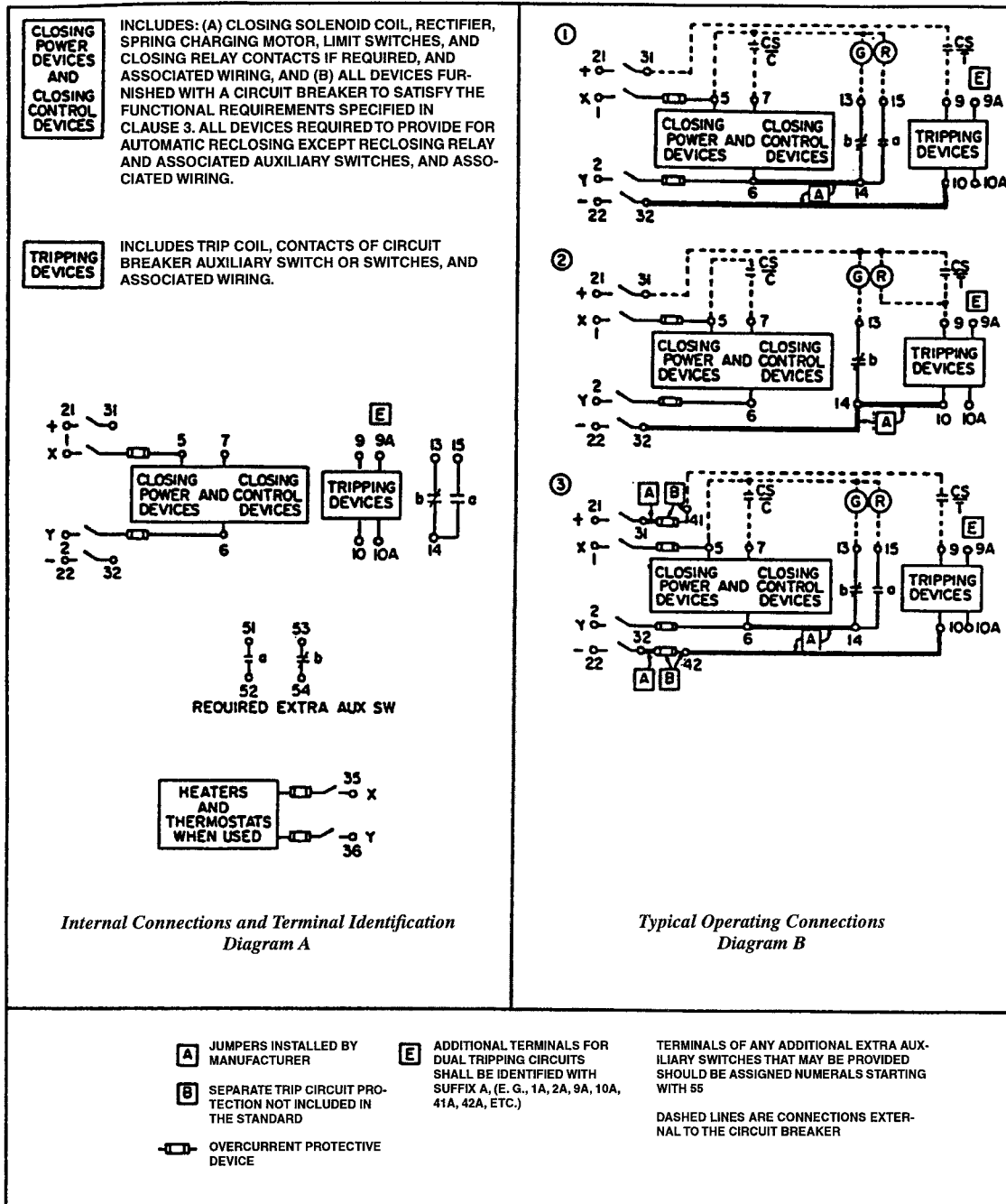

Figure 2—Circuit breaker intended for use in metal-clad switchgear, where

- The closing power is ac
- The closing control is ac
- The tripping control is dc

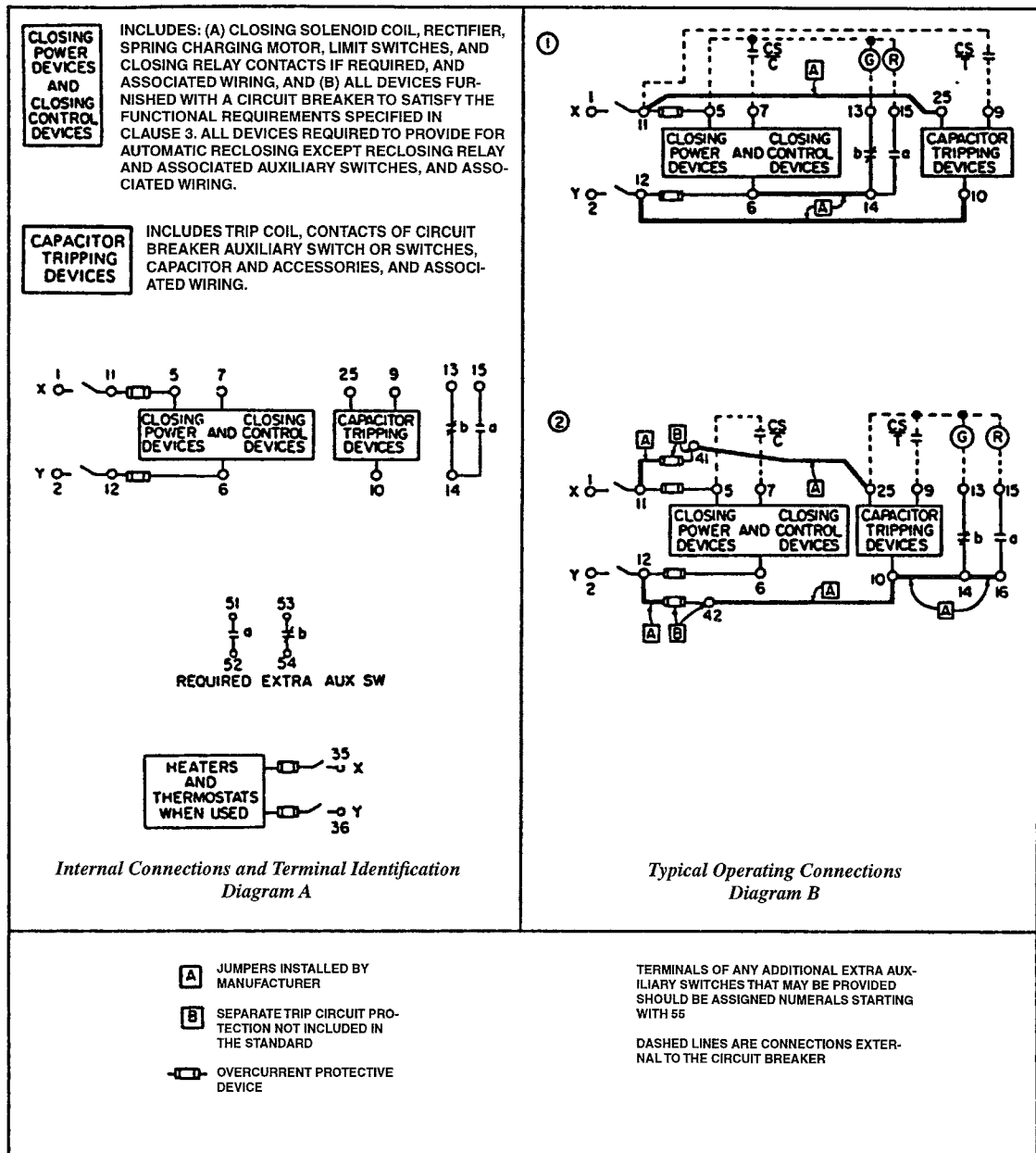

Figure 3—Circuit breaker intended for use in metal-clad switchgear, where

- The closing power is ac
- The closing control is ac
- The tripping control is by capacitor tripping devices

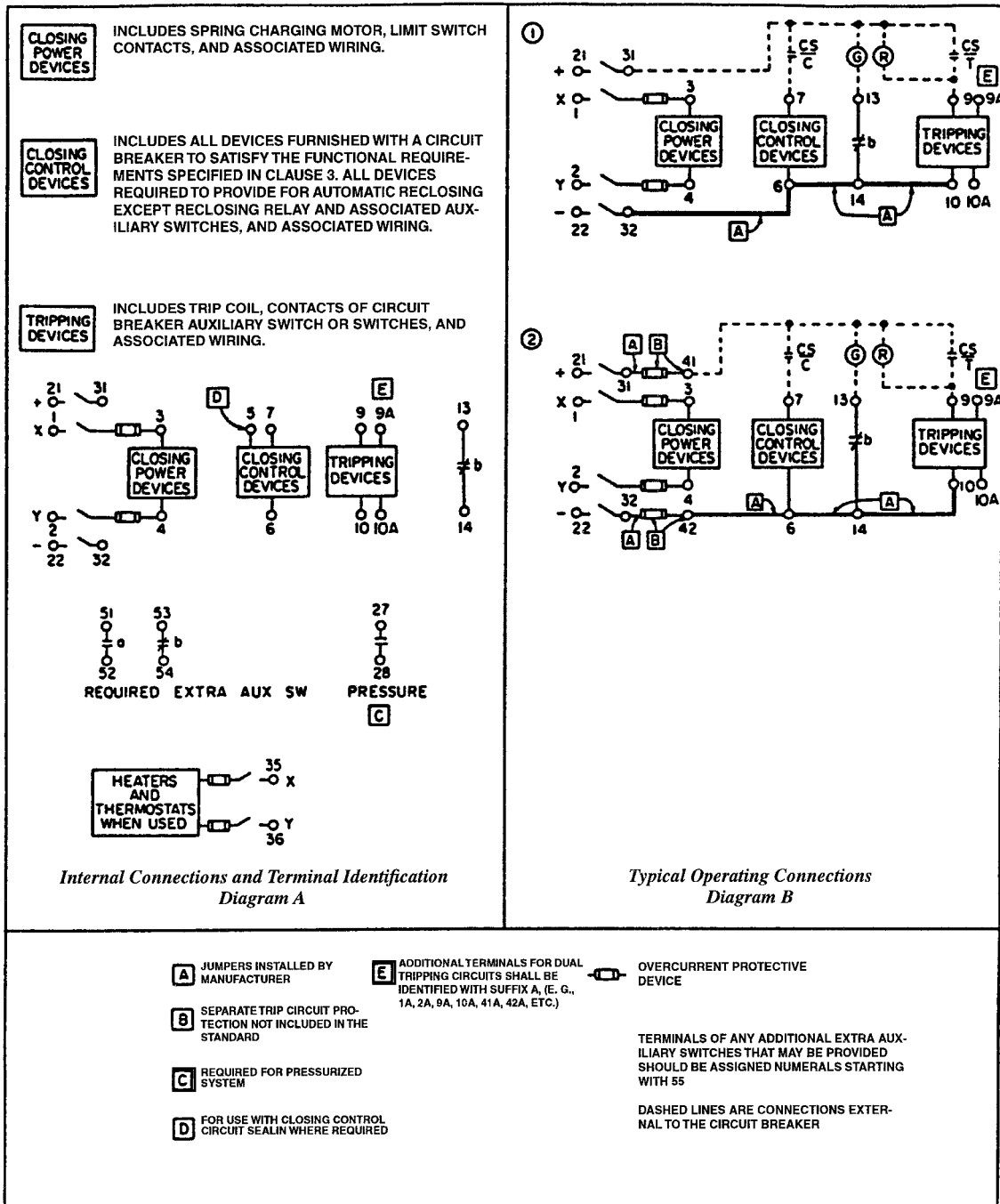

Figure 4—Circuit breaker intended for use in metal-clad switchgear, where

- The closing power is ac
- The closing control is dc
- The tripping control is dc

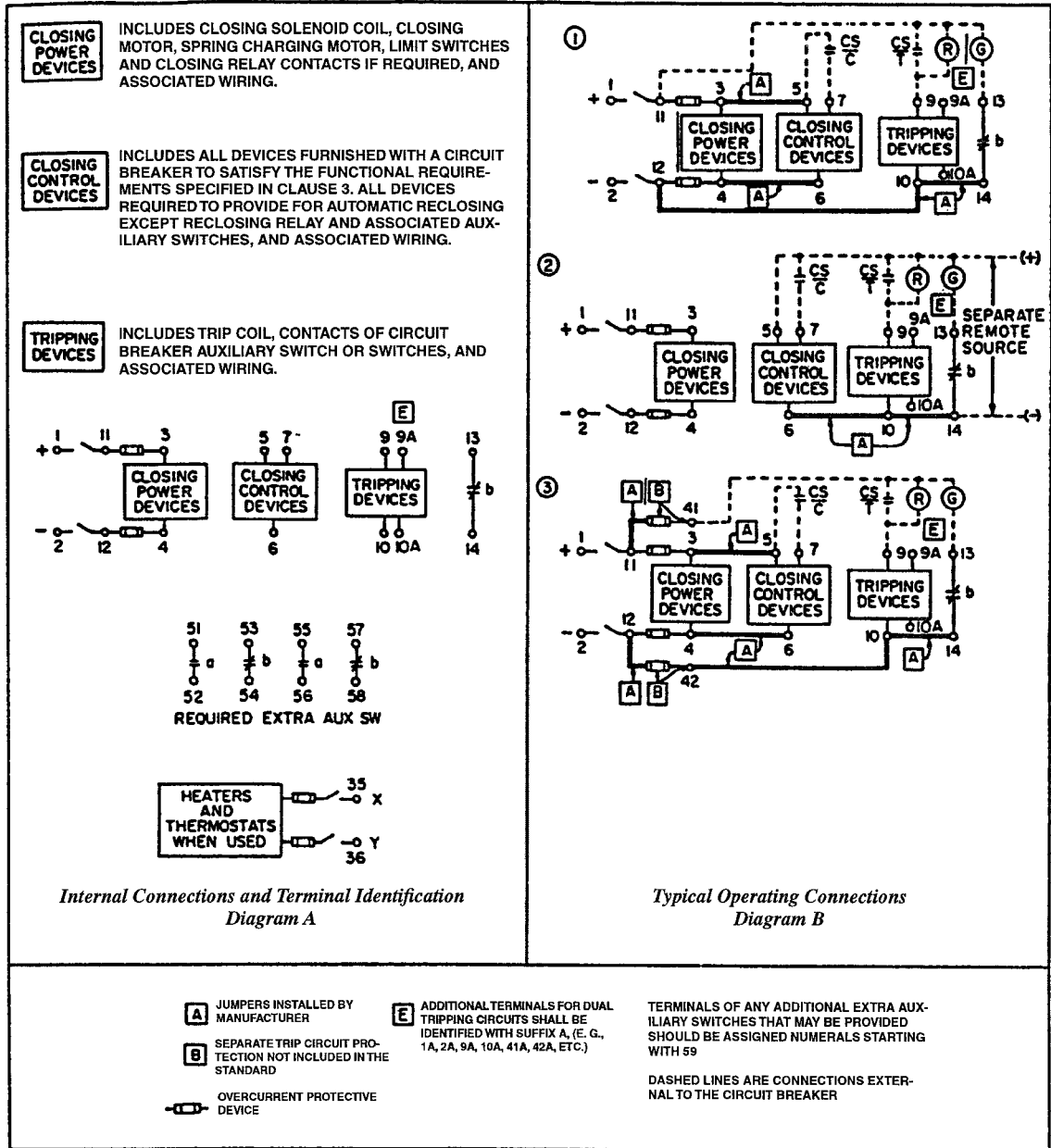

Figure 5—Circuit breaker NOT intended for use in metal-clad switchgear, where

- The closing power is dc
- The closing control is dc
- The tripping control is dc

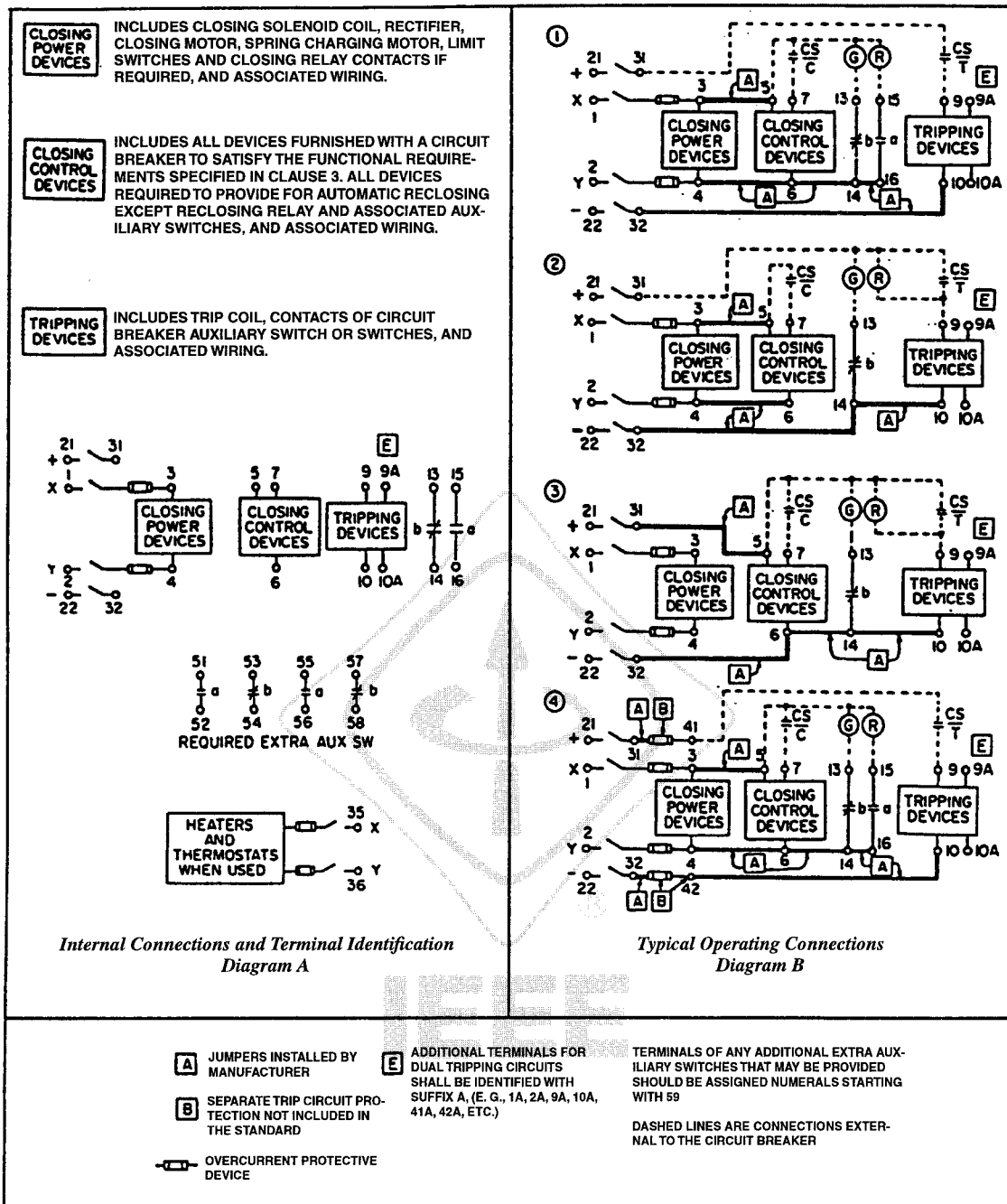

Figure 6—Circuit breaker NOT intended for use in metal-clad switchgear, where

- The closing power is ac
- The closing control is ac or dc
- The tripping control is dc

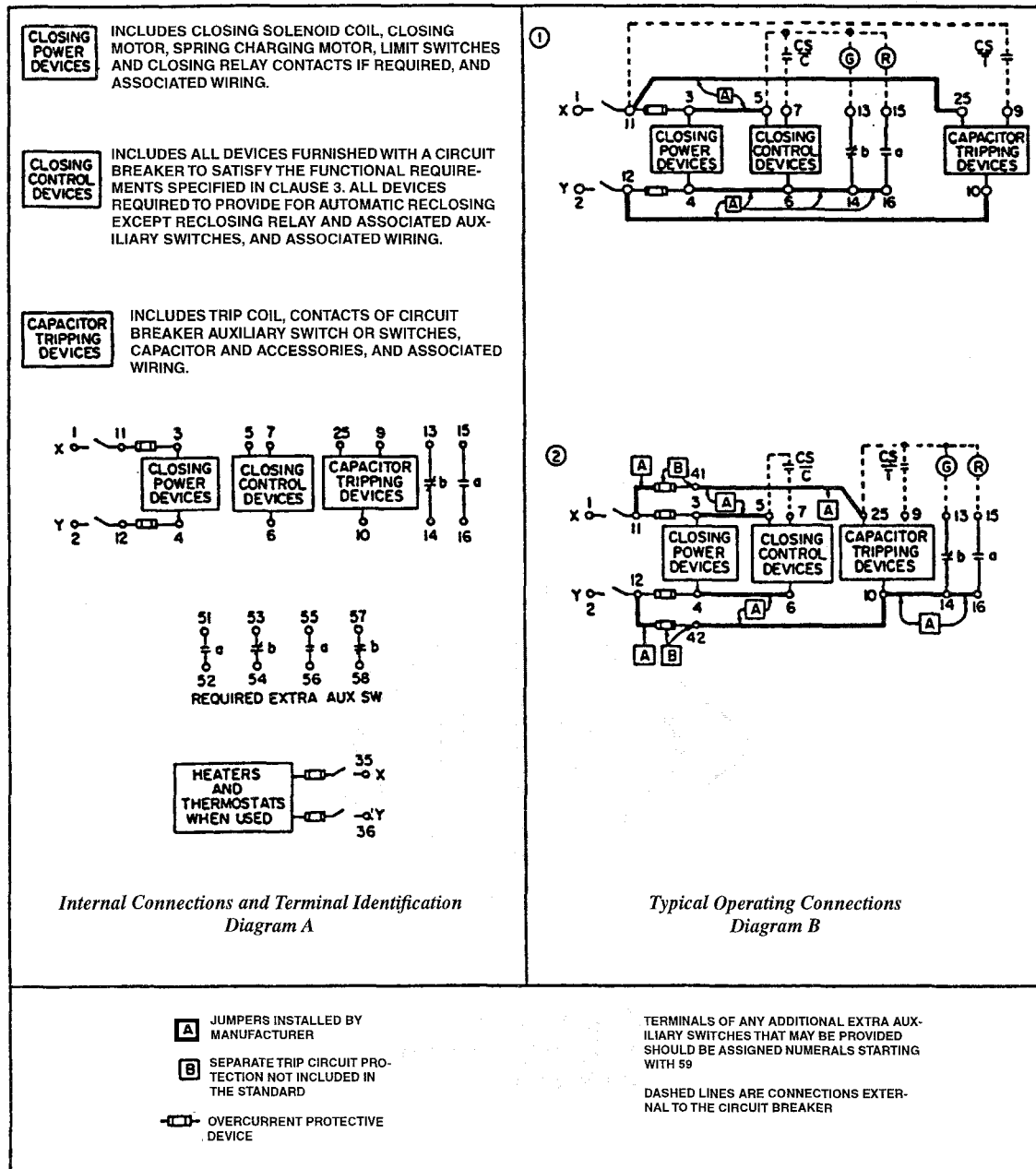

Figure 7—Circuit breaker NOT intended for use in metal-clad switchgear, where

- The closing power is ac
- The closing control is ac
- The tripping control is by capacitor tripping devices

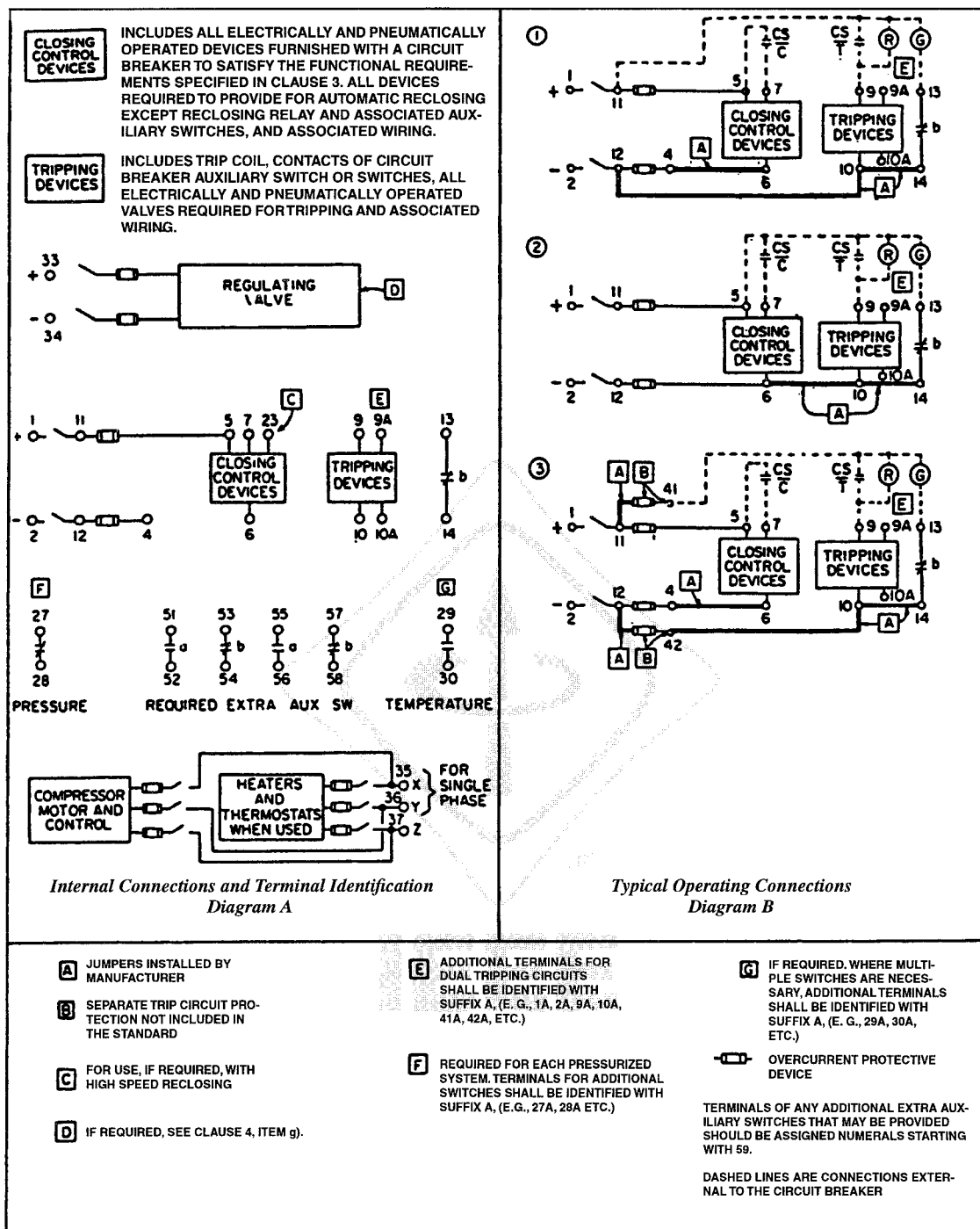

Figure 8—Pneumatically—or hydraulically—operated circuit breaker NOT intended for use in metal-clad switchgear, where

- The closing control is dc
- The tripping control is dc